

**HOBART**701 S Ridge Avenue, Troy, OH 45374  
1-888-4HOBART • www.hobartcorp.com**ACCESS – CLA SEMI-AUTO LABELING SYSTEM****HOBART****STANDARD FEATURES**

- Access/CLA semi-automatic labeling system weighs and labels up to 28 packages per minute
- Conveyor scale weighs up to 30 lb. x .01 increments
- Simple, reliable operation
- Left to right or right to left configurations
- 4-position swivel wand lets you rotate labels in all four directions
- Rugged stainless steel construction
- Easy to clean sanitary design

**MODELS**

- CLA2-1 – Compact Label Applier
- ULTIMSC-2 – Scale/Conveyor for CLA

Specifications, Details and Dimensions on Reverse Side.

**ACCESSORIES**

- ACCESS-WP3ST – Control panel post and BRKT-W3
- ACCESS-CLAKIT – Printer mounting adapter
- GRVCON-1 – 4' Gravity conveyor
- GRVCON-2 – 2' Fold down gravity conveyor (attaches to CLA)
- GRVCON-3 – 3' Fold down gravity conveyor (attaches to CLA)

**ACCESS – CLA SEMI-AUTO LABELING SYSTEM**

# ACCESS – CLA SEMI-AUTO LABELING SYSTEM



701 S Ridge Avenue, Troy, OH 45374  
1-888-4HOBART • www.hobartcorp.com

## SPECIFICATIONS

**CONSTRUCTION:** Heavy gauge stainless steel frame, legs and panels

**DIMENSIONS: System** – 22"D x 42"W x 40"H (65"H with EPP Printer & EPCP Control Panel)

**ELECTRICAL: CLA** – 120/208-240 (3 wire)/60/1; 14.5/8.0 amps

**SHIPPING WEIGHT: CLA2-1** – 261 lbs.; **ULTIMSC-2** – 36 lbs.; **ACCESS-W3PST** – 5 lbs. (total 305 lbs.)

## DETAILS AND DIMENSIONS

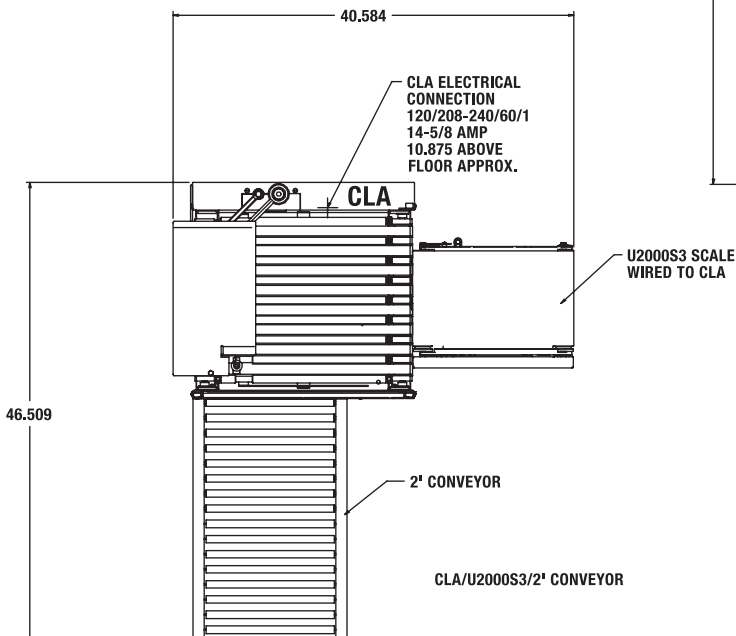
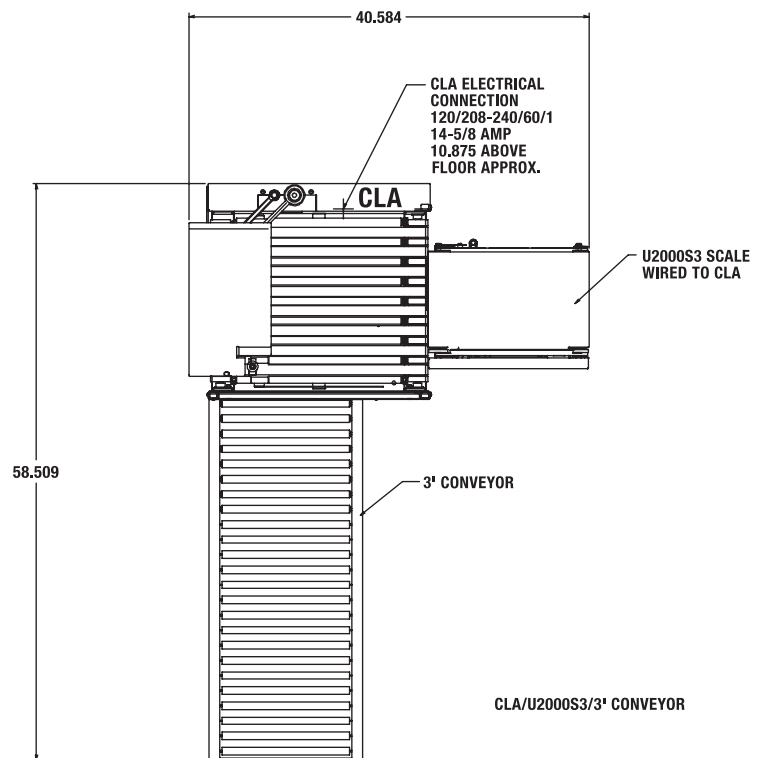
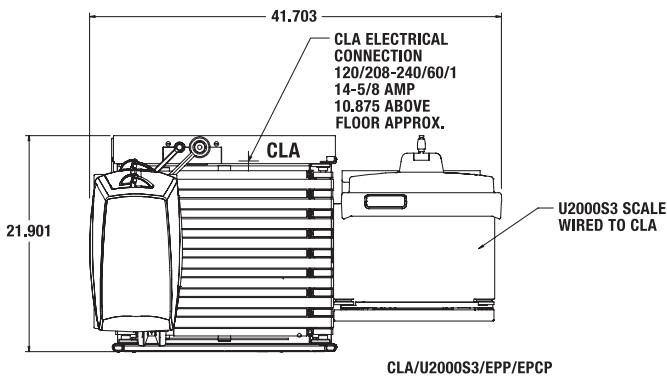

As continued product improvement is a policy of Hobart, specifications are subject to change without notice.