



701 S Ridge Avenue, Troy, OH 45374
1-888-4HOBART • www.hobartcorp.com

TURBOWASH II WITH SCRAPPER



TURBOWASH II WITH SCRAPPER

STANDARD FEATURES

- Type 304 polished stainless steel construction
- 14 gauge stainless tanks and drain boards
- 11" high x 2½" deep back splash
- Stainless steel pump and impeller
- Self-draining pump
- Sink front trim panel
- Eight 1½" diameter wash nozzles
- Removable, welded H frame leg sets and adjustable bullet feet
- Detachable and adjustable height cross rails
- Dual inlet strainers
- Centrifugal pump with 4" diameter intake and 3" diameter outlet
- 2 H.P. totally enclosed (TEFC) wash pump motor with permanently sealed bearings
- Low water protection for wash pump motor
- Inherent motor overload protection, manual reset
- 20"L x 16"W x 5¾"D deep scrapping sink or 28"L x 16¾"W x 11"D deep scrapping sink with 27"L x 18¾"W x 4¾"D deep shelf

DIRECTION FROM SOILED TO CLEAN END

- Right to Left Left to Right

VOLTAGE

- 208-240/60/1 208-240/60/3 480/60/3

OPTIONS AT ADDITIONAL COST

- 1½" IPS scrapper drain (shipped loose)
- 2" IPS sink drains (shipped loose)
- 2" IPS sink drains w/overflow (drains shipped loose)
- ¾" mixing faucets (shipped loose) Qty. _____
- ½" pre-rinse spray (shipped loose)
- Wash sink heater with high temperature and low water protection
- Adjustable (by Hobart service) pump shutdown timer
- High volume wash sink sump (12" x 12" x 3½" deep) with removable strainer
- Wash sink separator available (for wash sinks 42" or larger)
- Auto fill
- Utensil basket
- Hobart disposer with separate or single point electrical connection
- 15" deep over shelves with wall brackets Qty. _____
- 4' over shelf _____
- 6' over shelf _____
- 8' over shelf _____
- 10' over shelf (split 6' and 4') _____
- 12' over shelf (split 6' and 6') _____
- 14' over shelf (split 8' and 6') _____
- 16' over shelf (split 8' and 8') _____
- 18' over shelf (split 6', 4' and 8') _____
- 20' over shelf (split 2'-6' and 2'-4') _____
- Under shelf for clean end drain boards 30" and over
- Pan rack, 7 pan capacity

Specifications, Details and Dimensions on Inside and Back.



TURBOWASH II WITH 20" SCRAPPER

HOBART

701 S Ridge Avenue, Troy, OH 45374
1-888-4HOBART • www.hobartcorp.com

DETAILS AND DIMENSIONS

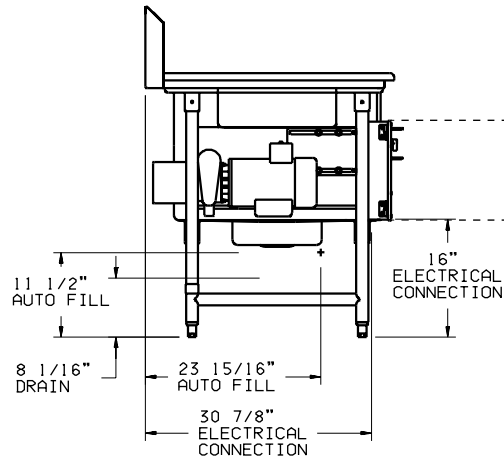
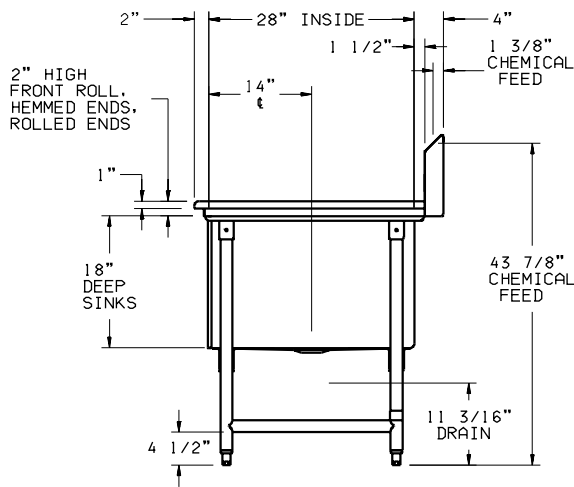
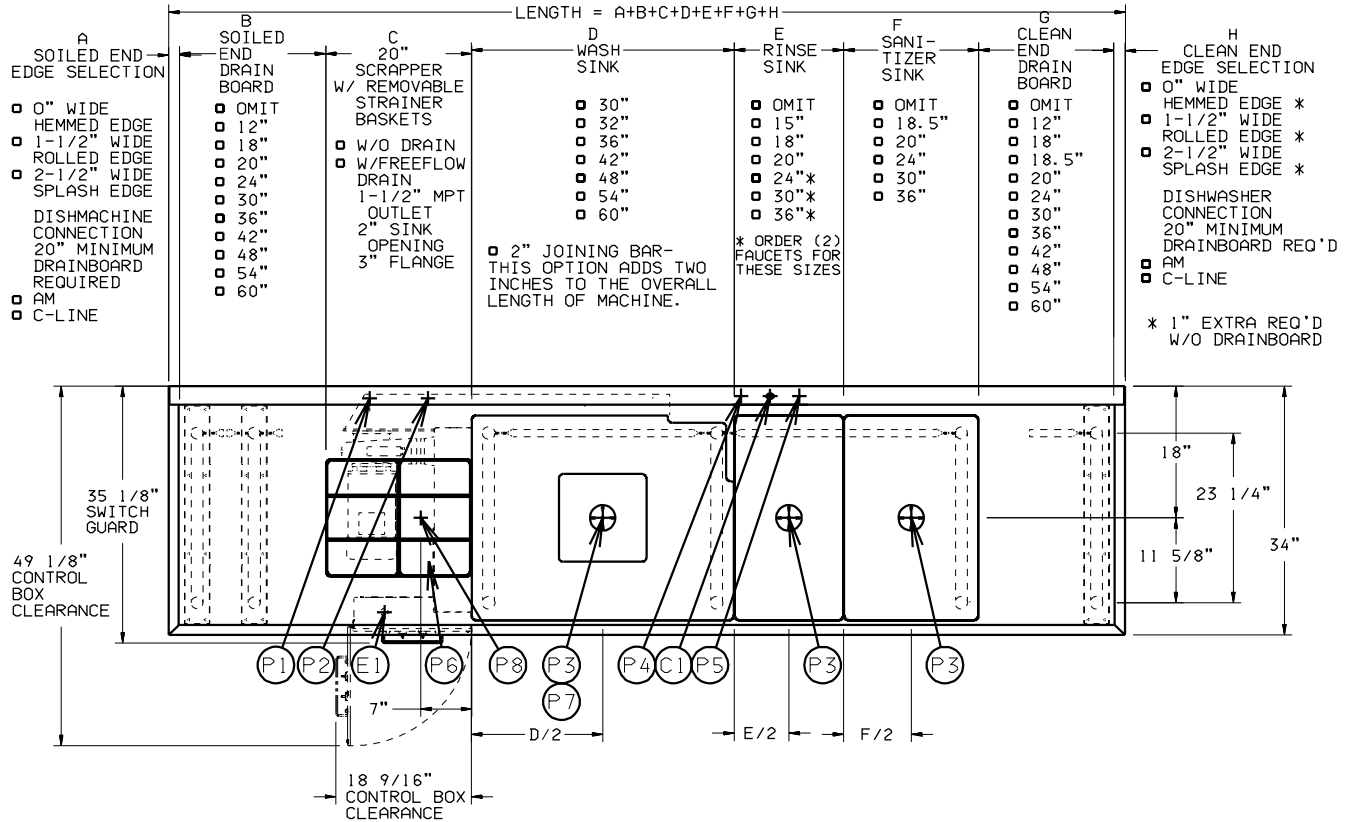

749866
TurboWash II
W/20" SCRAPPER
L-R OPERATION
REV. D



701 S Ridge Avenue, Troy, OH 45374
1-888-4HOBART • www.hobartcorp.com

TURBOWASH II WITH 20" SCRAPPER

- LEGEND**
- C1 CHEMICAL FEED CONNECTION: (OVER PRIMARY FAUCET), 1" DIA. HOLE FOR HOSE GROMMET, 43-7/8" AFF.
 - E1 ELECTRICAL CONNECTION: MOTORS & CONTROLS (INCLUDES ELECTRIC HEAT WHEN ORDERED), 3/4" CONDUIT, 16" AFF.
 - P1 HOT WATER CONNECTION: PRE-RINSE SPRAYER (WHEN ORDERED), 1/2" FPT, 36-15/16" AFF.
 - P2 COLD WATER CONNECTION: PRE-RINSE SPRAYER (WHEN ORDERED), 1/2" FPT, 36-15/16" AFF.
 - P3 SINK DRAINS: (1-3 CONNECTIONS-WHEN ORDERED), 2" MPT, 11-3/16" AFF.
 - P4 HOT WATER CONNECTION: MIXING FAUCET (WHEN ORDERED), 3/4" FPT, 36-5/8" AFF.
 - P5 COLD WATER CONNECTION: MIXING FAUCET (WHEN ORDERED), 3/4" FPT, 36-5/8" AFF.
 - P6 HOT WATER CONNECTION: AUTO FILL (WHEN ORDERED), 3/4" FPT, 11-1/2" AFF.
 - P7 WASH SINK WITH STRAINER DRAIN CONNECTION (WHEN ORDERED), 2" MPT EXTERNAL THREAD, 8-1/16" AFF.
 - P8 SCRAPPER DRAIN: (WHEN ORDERED) 1-1/2" MPT, 25-5/8" AFF.
- ALL DIMENSIONS TAKEN FROM FINISHED FLOOR LINE MAY INCREASE 3/4" OR DECREASE 1/2" DEPENDING ON LEG ADJUSTMENT.
RECOMMENDED 7-3/4" AFF WALL DRAIN LOCATION.

WARNING
ELECTRICAL AND GROUNDING CONNECTIONS MUST COMPLY WITH THE APPLICABLE PORTIONS OF THE NATIONAL ELECTRICAL CODE AND/OR OTHER LOCAL ELECTRICAL CODES.
PLUMBING CONNECTIONS MUST COMPLY WITH APPLICABLE SANITARY, SAFETY, AND PLUMBING CODES.

TurboWash WITH ELECTRIC HEAT			
ELEC. SPECS.	RATED AMPS	MINIMUM SUPPLY CIRCUIT CONDUCTOR AMPACITY	MAXIMUM OVERCURRENT PROTECTIVE DEVICE
208-240/60/1	18.2	25	25
208-240/60/3	15.1	20	20
480/60/3	7.6	15	15

TurboWash (W/O ELECTRIC HEAT)			
ELEC. SPECS.	RATED AMPS	MINIMUM SUPPLY CIRCUIT CONDUCTOR AMPACITY	MAXIMUM OVERCURRENT PROTECTIVE DEVICE
208-240/60/1	8.0	15	15
208-240/60/3	4.8	15	15
480/60/3	2.4	15	15

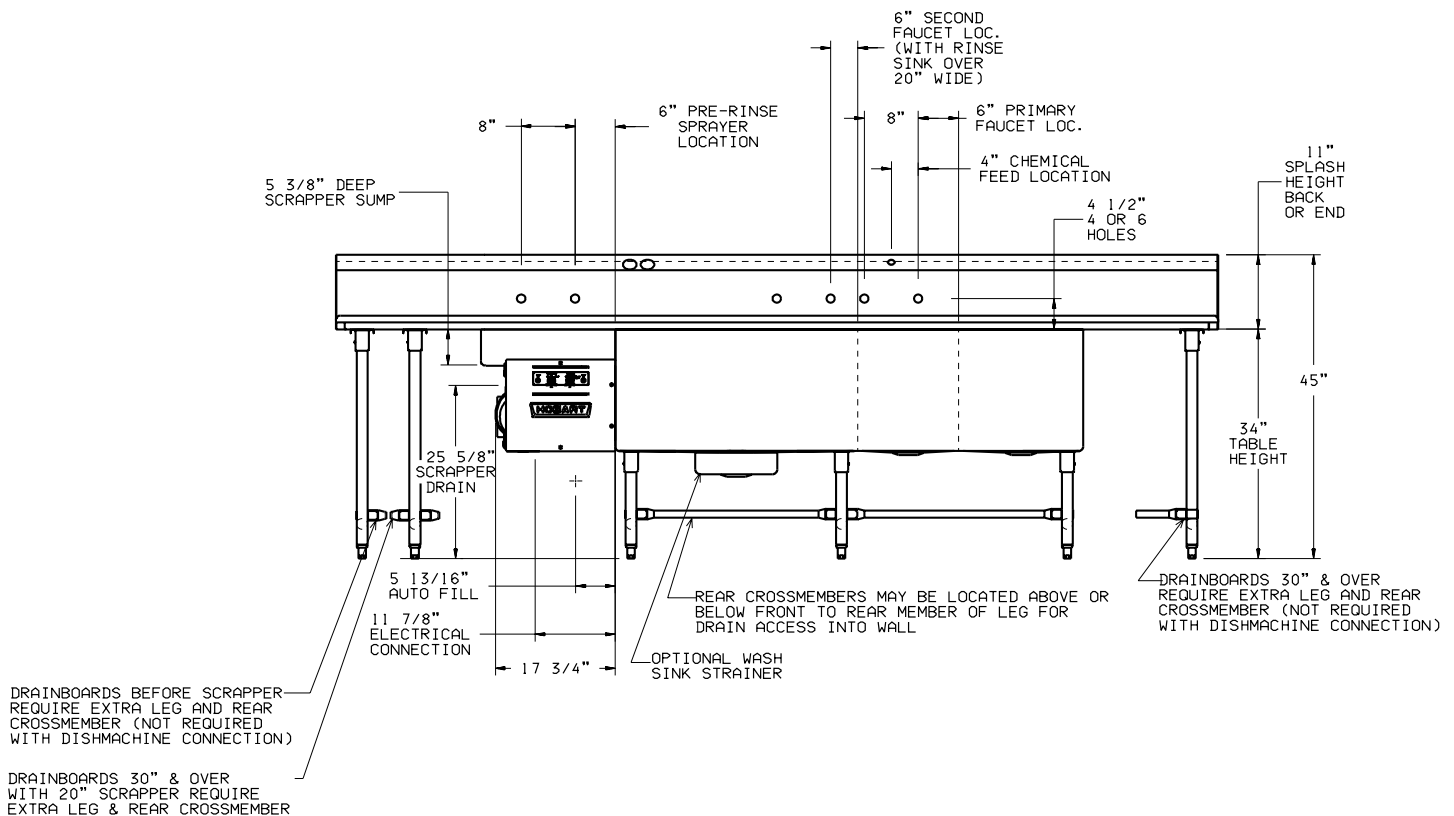

TURBOWASH II WITH 36" SCRAPER

HOBART

701 S Ridge Avenue, Troy, OH 45374
1-888-4HOBART • www.hobartcorp.com

DETAILS AND DIMENSIONS

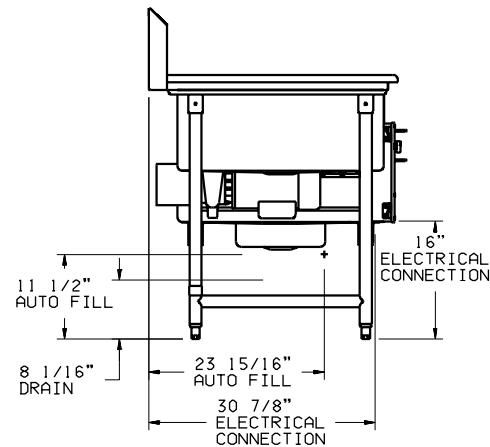
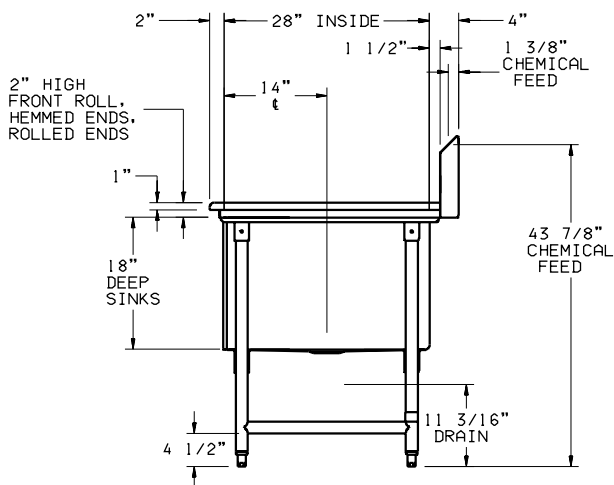
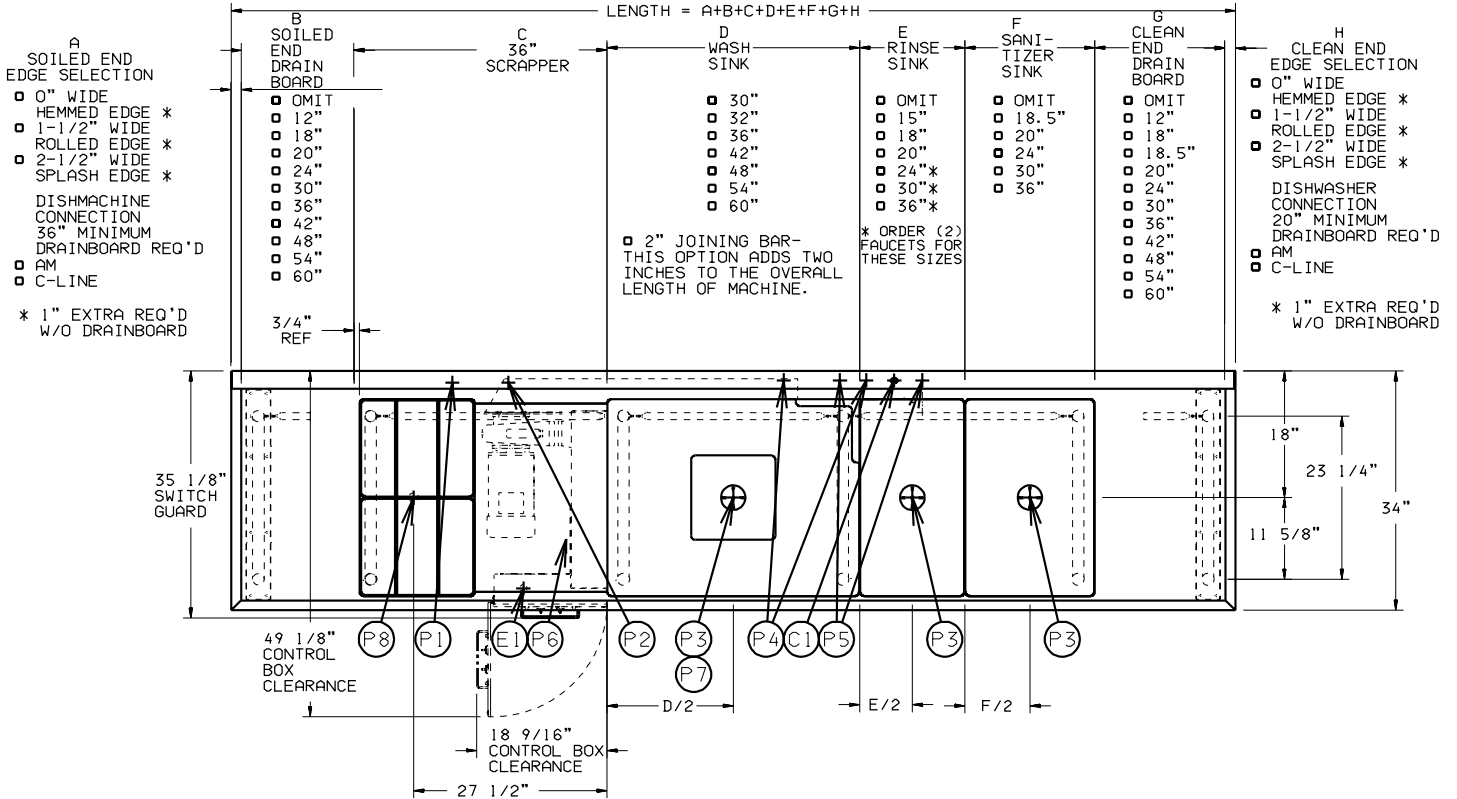

749867
TurboWash II
w/36" SCRAPER
HIGH VOLUME
L-R OPERATION
REV. D



701 S Ridge Avenue, Troy, OH 45374
1-888-4HOBART • www.hobartcorp.com

TURBOWASH II WITH 36" SCRAPER

- LEGEND**
- CONNECTION INFORMATION**
(XAFF - ABOVE FINISHED FLOOR)
- C1 CHEMICAL FEED CONNECTION: (OVER PRIMARY FAUCET), 1" DIA. HOLE FOR HOSE GROMMET, 43-7/8" AFF.
 - E1 ELECTRICAL CONNECTION: MOTORS & CONTROLS (INCLUDES ELECTRIC HEAT WHEN ORDERED), 3/4" CONDUIT, 16" AFF.
 - P1 HOT WATER CONNECTION: PRE-RINSE SPRAYER (WHEN ORDERED), 1/2" FPT, 36-15/16" AFF.
 - P2 COLD WATER CONNECTION: PRE-RINSE SPRAYER (WHEN ORDERED), 1/2" FPT, 36-15/16" AFF.
 - P3 SINK DRAINS: (1-3 CONNECTIONS-WHEN ORDERED), 2" MPT, 11-3/16" AFF.
 - P4 HOT WATER CONNECTION: MIXING FAUCET (WHEN ORDERED), 3/4" FPT, 36-5/8" AFF.
 - P5 COLD WATER CONNECTION: MIXING FAUCET (WHEN ORDERED), 3/4" FPT, 36-5/8" AFF.
 - P6 HOT WATER CONNECTION: AUTO FILL (WHEN ORDERED), 3/4" FPT, 11-1/2" AFF.
 - P7 WASH SINK WITH STRAINER DRAIN CONNECTION (WHEN ORDERED), 2" MPT, 8-1/16" AFF.
 - P8 SCRAPER DRAIN: (WHEN ORDERED) 1-1/2" MPT, 19-3/4" AFF.
- ALL DIMENSIONS TAKEN FROM FINISHED FLOOR LINE MAY INCREASE 3/4" OR DECREASE 1/2" DEPENDING ON LEG ADJUSTMENT.
RECOMMENDED 7-3/4" AFF WALL DRAIN LOCATION.

WARNING
ELECTRICAL AND GROUNDING CONNECTIONS MUST COMPLY WITH THE APPLICABLE PORTIONS OF THE NATIONAL ELECTRICAL CODE AND/OR OTHER LOCAL ELECTRICAL CODES.
PLUMBING CONNECTIONS MUST COMPLY WITH APPLICABLE SANITARY, SAFETY, AND PLUMBING CODES.

TurboWash WITH ELECTRIC HEAT			
ELEC. SPECS.	RATED AMPS	MINIMUM SUPPLY CIRCUIT CONDUCTOR AMPACITY	MAXIMUM OVERCURRENT PROTECTIVE DEVICE
208-240/60/1	18.2	25	25
208-240/60/3	15.1	20	20
480/60/3	7.6	15	15

TurboWash (W/O ELECTRIC HEAT)			
ELEC. SPECS.	RATED AMPS	MINIMUM SUPPLY CIRCUIT CONDUCTOR AMPACITY	MAXIMUM OVERCURRENT PROTECTIVE DEVICE
208-240/60/1	8.0	15	15
208-240/60/3	4.8	15	15
480/60/3	2.4	15	15

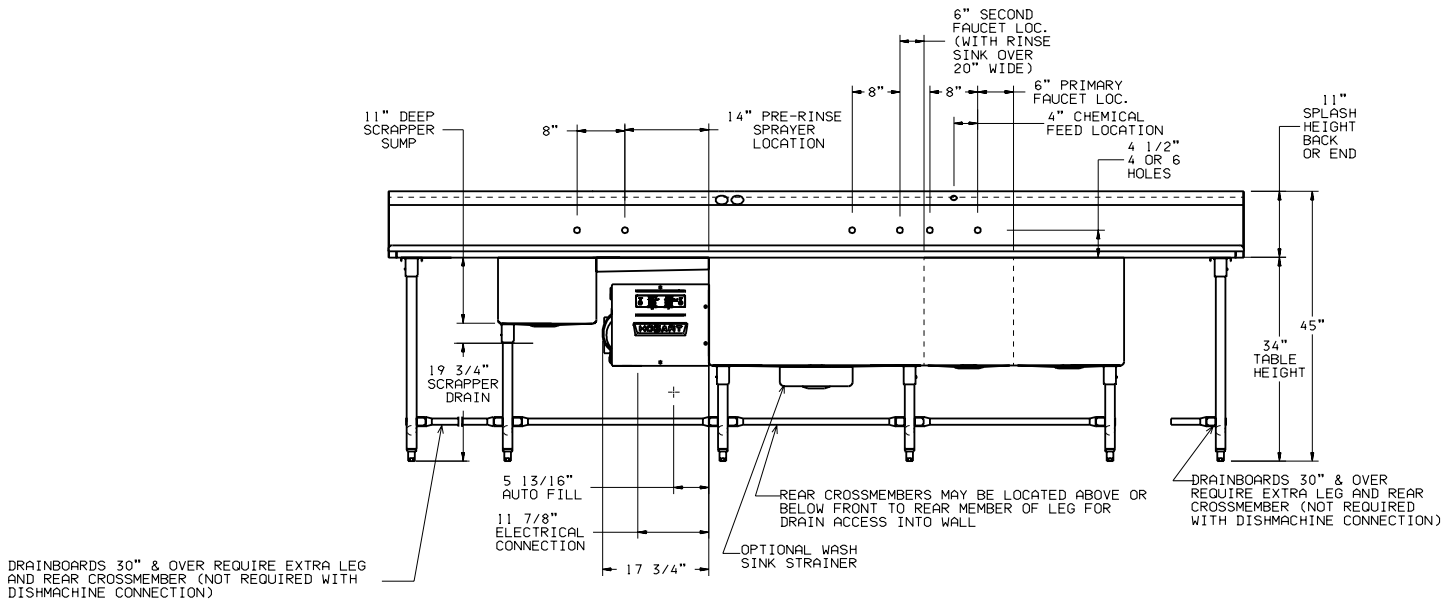

TURBOWASH II WITH DISPOSER

HOBART

701 S Ridge Avenue, Troy, OH 45374
1-888-4HOBART • www.hobartcorp.com

DETAILS AND DIMENSIONS

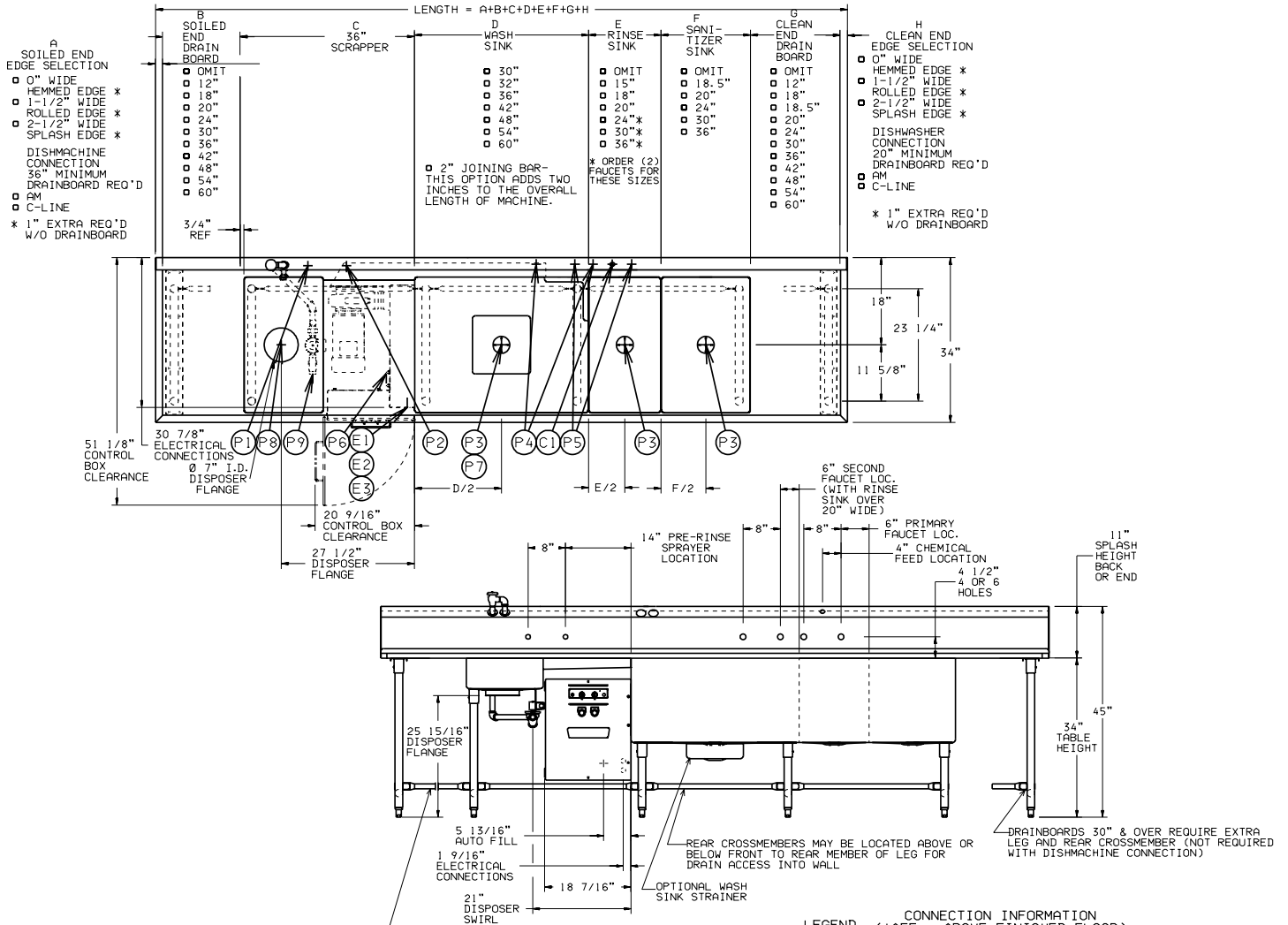

DRAINBOARDS 30" & OVER REQUIRE EXTRA LEG AND REAR CROSSMEMBER (NOT REQUIRED WITH DISHWASHER CONNECTION)

WARNING
ELECTRICAL AND GROUNDING CONNECTIONS MUST COMPLY WITH THE APPLICABLE PORTIONS OF THE NATIONAL ELECTRICAL CODE AND/OR OTHER LOCAL ELECTRICAL CODES. PLUMBING CONNECTIONS MUST COMPLY WITH APPLICABLE SANITARY, SAFETY, AND PLUMBING CODES.

TurboWash WITH S.P.E.C. WITH ELECTRIC HEAT			
ELEC. SPECS.	RATED AMPS	MINIMUM SUPPLY CIRCUIT CONDUCTOR AMPACITY	MAXIMUM OVERCURRENT PROTECTIVE DEVICE
208-240/60/1	29.0	40	40
208-240/60/3	24.1	35	35
480/60/3	11.6	15	15

TurboWash WITH S.P.E.C. (W/O ELECTRIC HEAT)			
ELEC. SPECS.	RATED AMPS	MINIMUM SUPPLY CIRCUIT CONDUCTOR AMPACITY	MAXIMUM OVERCURRENT PROTECTIVE DEVICE
208-240/60/1	18.8	25	25
208-240/60/3	13.8	20	20
480/60/3	6.4	15	15

CONNECTION INFORMATION LEGEND (*AFF - ABOVE FINISHED FLOOR)

- C1 CHEMICAL FEED CONNECTION: (OVER PRIMARY FAUCET), 1" DIA. HOLE FOR HOSE GROMMET, 1.43"-7/8" AFF.
- E1 ELECTRICAL CONNECTION: MOTORS/CONTROLS W/O S.P.E.C. (INCLUDES ELECTRIC HEAT WHEN ORDERED), 3/4" CONDUIT, 12" AFF.
- E2 ELECTRICAL CONNECTION: DISPOSER MOTOR W/O S.P.E.C., 3/4" CONDUIT, 10" AFF.
- E3 ELECTRICAL CONNECTION: S.P.E.C. MOTORS/CONTROLS AND DISPOSER (INCLUDES ELECTRIC HEAT WHEN ORDERED), 1" CONDUIT, 12" AFF.
- P1 HOT WATER CONNECTION: PRE-RINSE SPRAYER (WHEN ORDERED), 1/2" FPT, 36-15/16" AFF.
- P2 COLD WATER CONNECTION: PRE-RINSE SPRAYER (WHEN ORDERED), 1/2" FPT, 36-15/16" AFF.
- P3 SINK DRAINS: (1-3 CONNECTIONS-WHEN ORDERED), 2" MPT, 11-3/16" AFF.
- P4 HOT WATER CONNECTION: MIXING FAUCET (WHEN ORDERED), 3/4" FPT, 36-5/8" AFF.
- P5 COLD WATER CONNECTION: MIXING FAUCET (WHEN ORDERED), 3/4" FPT, 36-5/8" AFF.
- P6 HOT WATER CONNECTION: AUTO FILL (WHEN ORDERED), 3/4" FPT, 11-1/2" AFF.
- P7 WASH SINK WITH STRAINER DRAIN CONNECTION: (WHEN ORDERED), 2" MPT, 8-1/16" AFF.
- P8 DISPOSER FLANGE CONNECTION: DISPOSER FLANGE (WHEN ORDERED), 7" I.D., 25-15/16" AFF.
- P9 COLD WATER CONNECTION: DISPOSER SWIRL (WHEN ORDERED), 3/4" FPT, 21-5/16" AFF.

ALL DIMENSIONS TAKEN FROM FINISHED FLOOR LINE MAY INCREASE 3/4" OR DECREASE 1/2" DEPENDING ON LEG ADJUSTMENT. RECOMMENDED 7-3/4" AFF WALL DRAIN LOCATION.

749869 TurboWash II
W/36" DISPOSER SCRAPPER
(WITH DISPOSER CONTROLS)
L-R OPERATION REV. D



701 S Ridge Avenue, Troy, OH 45374
1-888-4HOBART • www.hobartcorp.com

TURBOWASH II WITH DISPOSER

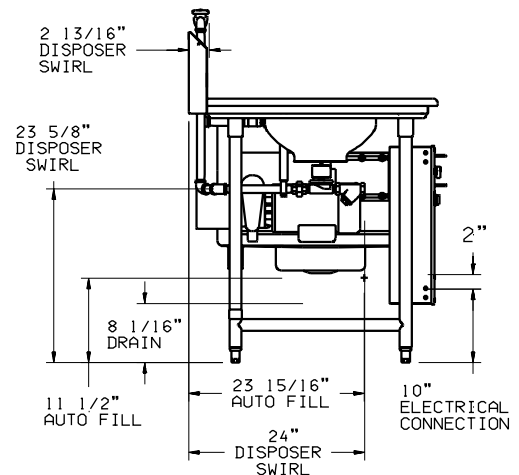
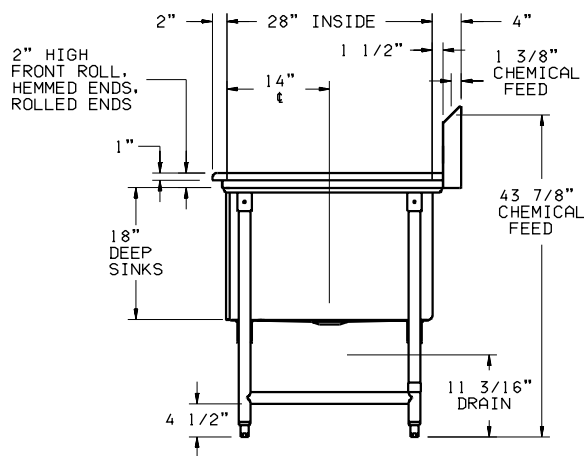
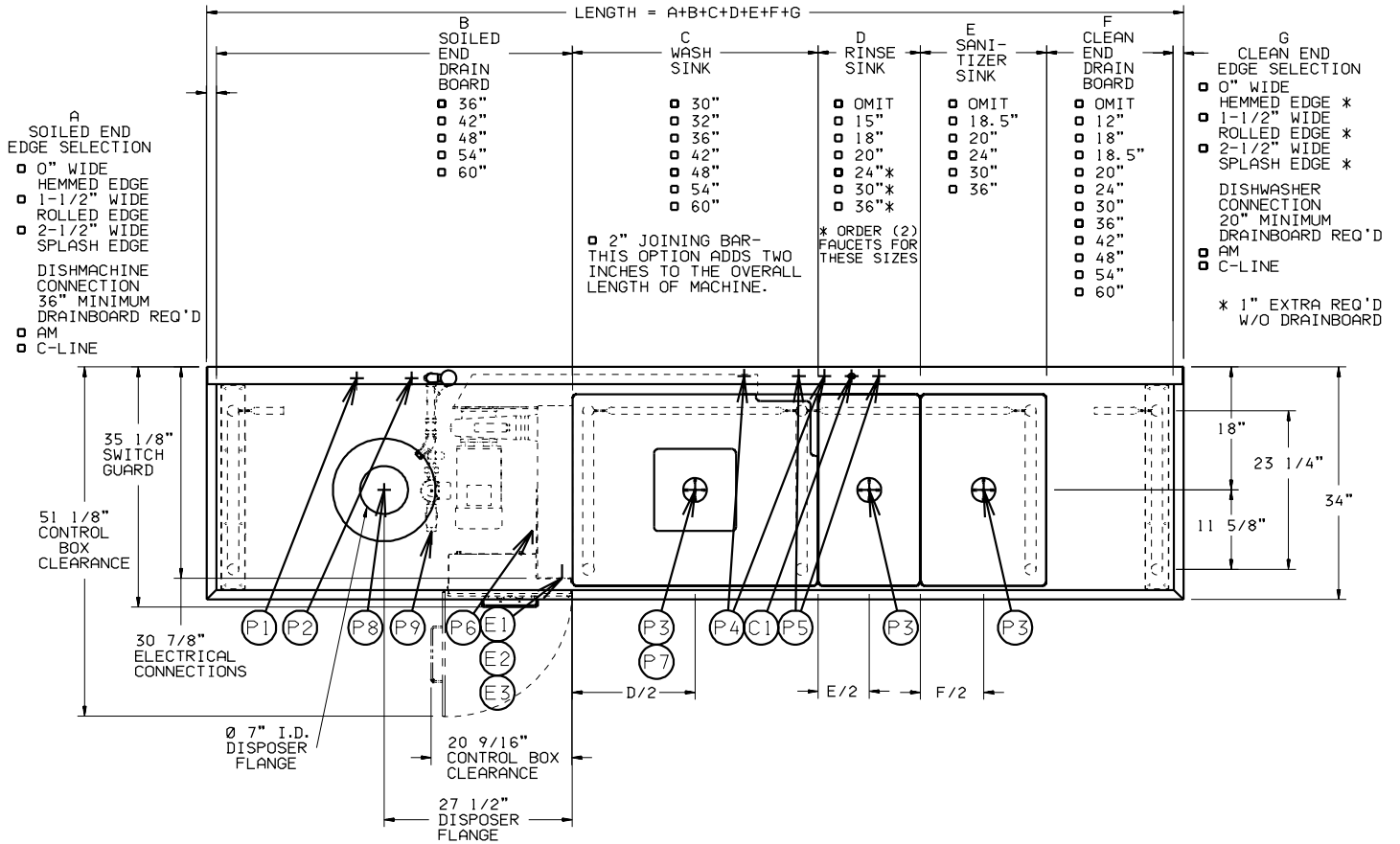

749871 TurboWash II
W/DISPOSER CONE/DRAINBOARD
(WITH DISPOSER CONTROLS)
L-R OPERATION REV. D

TURBOWASH II WITH DISPOSER

HOBART

701 S Ridge Avenue, Troy, OH 45374
1-888-4HOBART • www.hobartcorp.com

DETAILS AND DIMENSIONS

- LEGEND CONNECTION INFORMATION (*AFF ABOVE FINISHED FLOOR)
- C1 CHEMICAL FEED CONNECTION: (OVER PRIMARY FAUCET), 1" DIA. HOLE FOR HOSE GROMMET, 43-7/8" AFF.
 - E1 ELECTRICAL CONNECTION: MOTORS/CONTROLS W/O S.P.E.C. (INCLUDES ELECTRIC HEAT WHEN ORDERED), 3/4" CONDUIT, 12" AFF.
 - E2 ELECTRICAL CONNECTION: DISPOSER MOTOR W/O S.P.E.C., 3/4" CONDUIT, 10" AFF.
 - E3 ELECTRICAL CONNECTION: S.P.E.C. MOTORS/CONTROLS AND DISPOSER (INCLUDES ELECTRIC HEAT WHEN ORDERED), 1" CONDUIT, 12" AFF.
 - P1 HOT WATER CONNECTION: PRE-RINSE SPRAYER (WHEN ORDERED), 1/2" FPT, 38-15/16" AFF.
 - P2 COLD WATER CONNECTION: PRE-RINSE SPRAYER (WHEN ORDERED), 1/2" FPT, 38-15/16" AFF.
 - P3 SINK DRAINS: (1-3 CONNECTIONS-WHEN ORDERED), 2" MPT, 11-3/16" AFF.
 - P4 HOT WATER CONNECTION: MIXING FAUCET (WHEN ORDERED), 3/4" FPT, 38-5/8" AFF.
 - P5 COLD WATER CONNECTION: MIXING FAUCET (WHEN ORDERED), 3/4" FPT, 38-5/8" AFF.
 - P6 HOT WATER CONNECTION: AUTO FILL (WHEN ORDERED), 3/4" FPT, 11-1/2" AFF.
 - P7 WASH SINK WITH STRAINER DRAIN CONNECTION: (WHEN ORDERED), 2" MPT, 8-1/16" AFF.
 - P8 DISPOSER FLANGE CONNECTION: DISPOSER FLANGE (WHEN ORDERED), 7" I.D., 27-3/8" AFF.
 - P9 COLD WATER CONNECTION: DISPOSER SWIRL, (WHEN ORDERED), 3/4" FPT, 23-5/8" AFF.

ALL DIMENSIONS TAKEN FROM FINISHED FLOOR LINE MAY INCREASE 3/4" OR DECREASE 1/2" DEPENDING ON LEG ADJUSTMENT. RECOMMENDED 7-3/4" AFF WALL DRAIN LOCATION.

WARNING

ELECTRICAL AND GROUNDING CONNECTIONS MUST COMPLY WITH THE APPLICABLE PORTIONS OF THE NATIONAL ELECTRICAL CODE AND/OR OTHER LOCAL ELECTRICAL CODES. PLUMBING CONNECTIONS MUST COMPLY WITH APPLICABLE SANITARY, SAFETY, AND PLUMBING CODES.

TurboWash WITH S.P.E.C. WITH ELECTRIC HEAT			
ELEC. SPECS.	RATED AMPS	MINIMUM SUPPLY CIRCUIT CONDUCTOR AMPACITY	MAXIMUM OVERCURRENT PROTECTIVE DEVICE
208-240/60/1	29.0	40	40
208-240/60/3	24.1	35	35
480/60/3	11.6	15	15

TurboWash WITH S.P.E.C. (W/O ELECTRIC HEAT)			
ELEC. SPECS.	RATED AMPS	MINIMUM SUPPLY CIRCUIT CONDUCTOR AMPACITY	MAXIMUM OVERCURRENT PROTECTIVE DEVICE
208-240/60/1	18.8	25	25
208-240/60/3	13.8	20	20
480/60/3	6.4	15	15

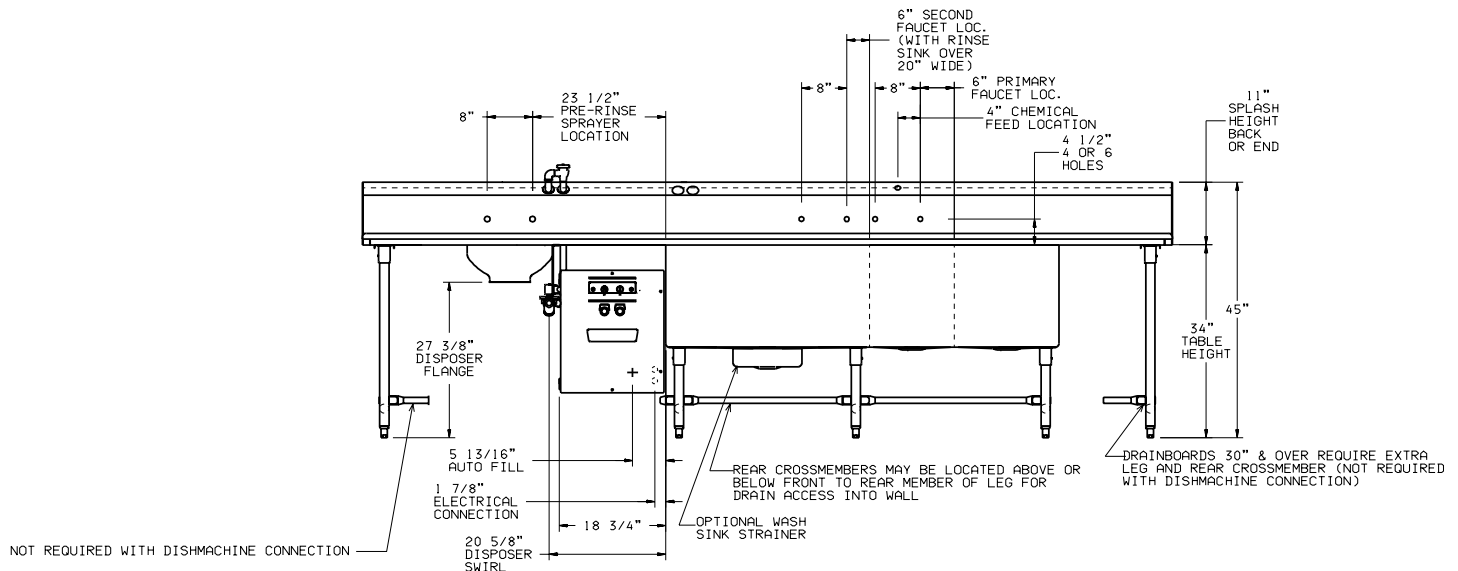

As continued product improvement is a policy of Hobart, specifications are subject to change without notice.